

# BASCO BIMETAL THERMOMETERS FOR ASPHALT PLANTS

## Specifications and Features

- Economical
- 3" or 5" dial available
- All Stainless steel construction, 1/4" dia stem (STD)
- Shatter Proof Glass Lens
- Standard external Reset
- Standard 1/2" NPT fitting
- Anodized Aluminum dial with black lettering with satin matte finish background
- Accurate to 1% of full scale (grade A, ASME B40.3)
- 1 year limited warranty against manufactured defects
- Dual °F/°C Range

## Options

- 1/4" NPT
- 3/4" NPT

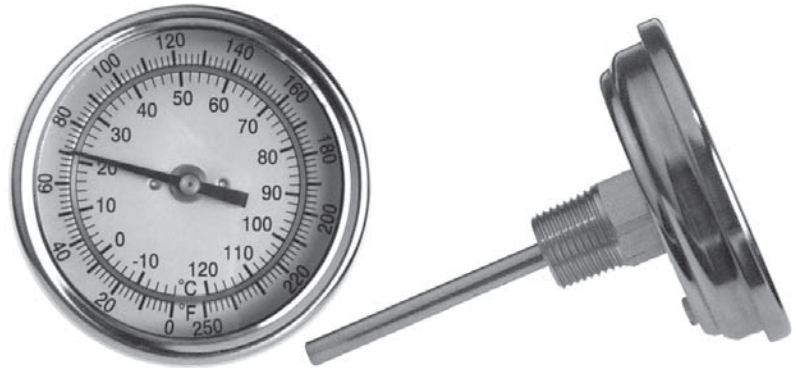

## How to order



Code	Models Description	Standard Stem lengths		Ranges (DUAL)				
		Code	inches	Code	Temperature	divisions		divisions
3A	3"dial centre back stem (90°)	02	2 1/2	02	* 25 - 125°F	1 °F	-5 - 50°C	1 °C
5A	5"dial centre back stem (90°)	04	4	04	-40 - 160°F	2 °F	-40 - 70°C	1 °C
3S	3"dial lower mount stem	06	6	05	0 - 200°F	2 °F	-10 - 90°C	1 °C
5S	5"dial lower mount stem	09	9	07	0 - 250°F	2 °F	-20 - 120°C	2 °C
CF	3"dial • Adjustable angle stem	12	12	08	50 - 300°F	2 °F	10 - 150°C	2 °C
AF	5"dial • Adjustable angle stem	15	15	09	50 - 500°F	5 °F	10 - 260°C	5 °C
		18	18	10	50 - 550°F	5 °F	10 - 290°C	5 °C
		24	24	11	150 - 750°F	5 °F	70 - 400°C	5 °C
	• See drawings below	36	36	12	200 - 1000°F	10 °F	100 - 500°C	5 °C

\* 4" minimum Stem length for this Range

## NOTES:

- Other ranges available (single scales)
- Other stem lengths up to 80 inches available on request
- Total Stem length includes the fitting
- Your LOGO on the dial: A minimum quantity order is required

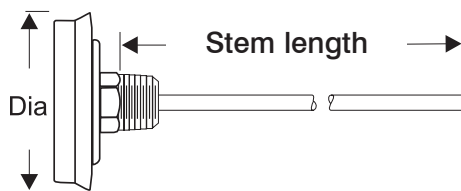

Model 3A and 5A

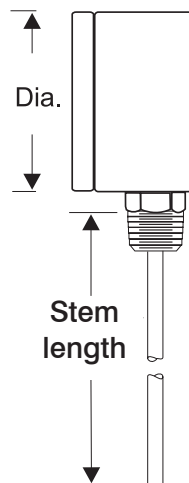

Model 3S and 5S

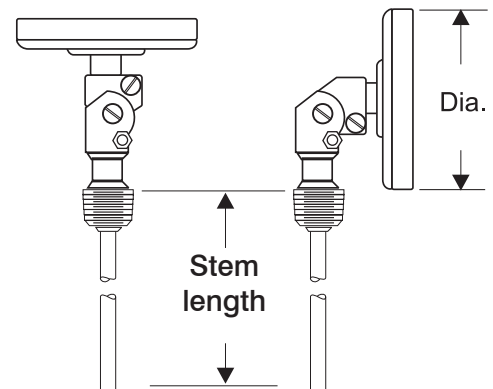

Model AF, CF



www.omnimetrix.com  
(514)-684-1004

# THERMOWELLS

## Specifications

- .260" dia. Bore
- 1/2" internal threads
- 3/4" NPT external (standard); 1" NPT available on special request
- 1/2" NPT available

3/4" NPT with lagging extension							
A	U	T	Q	Brass	Steel	St.St. 304	St.St. 316
6	2 1/2	2	-	L3B6	L3S6	L3G6	L3J6
9	4 1/2	3	3/4	L3B9	L3S9	L3G9	L3J9
12	7 1/2			L3B2	L3S2	L3G2	L3J2
15	10 1/2			L3B5	L3S5	L3G5	L3J5
18	13 1/2			L3B8	L3S8	L3G8	L3J8
24	19 1/2			L3BT	L3ST	L3GT	L3JT

3/4" NPT without lagging (1/2" NPT available)						
A	U	Q	Brass	Steel	St.St. 304	St.St. 316
2 1/2	1 3/8	3/4	S3B1	S3S1	S3G1	S3J1
4	2 1/2		S3B4	S3S4	S3G4	S3J4
6	4 1/2		S3B6	S3S6	S3G6	S3J6
9	7 1/2		S3B9	S3S9	S3G9	S3J9
12	10 1/2		S3B2	S3S2	S3G2	S3J2
15	13 1/2		S3B5	S3S5	S3G5	S3J5
18	16 1/2		S3B8	S3S8	S3G8	S3J8
24	22 1/2		S3BT	S3ST	S3GT	S3JT

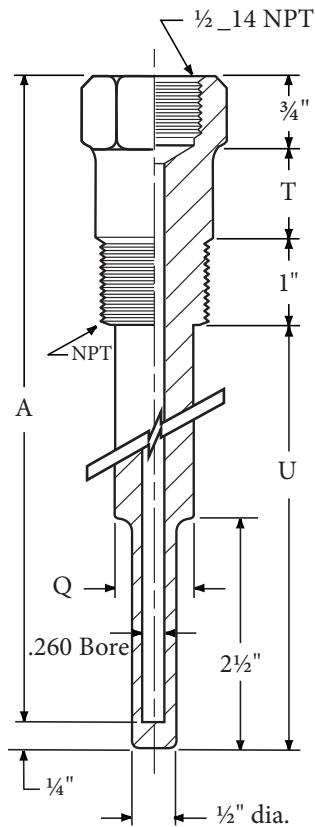

Model with or without lagging

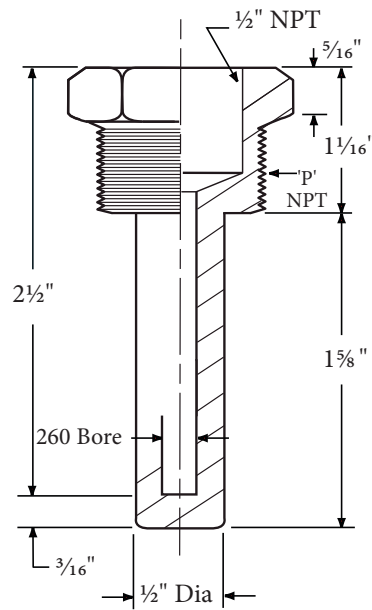

2 1/2" Reduced model



www.omnimetrix.com

(514)-684-1004